

Draft Regulator

FEATURES

- Furnace draft control for low-level positive or negative pressure on fast-responding loops.
- Minimum number of moving parts for low maintenance & long life even under the worst application conditions.
- Sequencing or non-sequencing modulation – enhanced performance and savings for any boiler application.
- exclusive synchronous stepping motor eliminates coast and provides reliable, precise positioning.
- Field-adjustable set point, damping, dead band and proportional band.
- Optional handwheel.

APPLICATION

The **Hays Cleveland Model R-09500-B0 Draft Regulator** is a simple, economical means to reduce smoke, conserve fuel, and comply with local air pollution ordinances. It provides automatic modulation of the outlet damper for any balanced draft or positive furnace pressure application. The electronic sensor/controller provides stable draft control even on difficult applications, such as those with high stacks, where rapid process fluctuation has rendered conventional draft controls (i.e., diaphragm-based types with mechanical switching circuitry) ineffective.

DESCRIPTION

The **Hays Cleveland Model R-09500-B0 Draft Regulator** is a combination draft sensor, controller, and actuating motor in a single compact enclosure with a removable cover. A solid-state electronic sensor and controller assembly features a piezo-resistive silicon amplifier capable of measuring either positive or negative pressures. The sensing element is temperature-compensated, and produces 1-6 VDC output directly proportional to the differential between atmospheric and process pressure.

Because of the high-frequency response of the sensing element, electronic damping circuitry is provided to filter out the “noise” typical of draft applications. The result is stable, precise damper positioning unattainable with draft controls relying on diaphragm-based draft measurement and mechanical switching circuitry. Now even the “noisiest” high-stack applications can be controlled effectively and economically!

R09500.04



Hays Cleveland Model R-09500-B0 Draft Regulator

All models offer a linear damper drive with 6-inch range of travel, and 30 or 60 second nominal stroke time (providing 75 or 150 pounds starting thrust range, respectively). A powerful 72 RPM impedance-protected synchronous stepping motor positions a drive tube over a linear range of travel. Inward and outward end switches shut off power to the motor whenever the drive tube reaches the fully extended or fully retracted position. On sequencing models, an additional switch signals the burner management system that the damper is open, as required by codes. There is no hunting or overheating under even the most unstable process conditions.

Compared to previous draft controls, the **R-09500-B0 Draft Regulator's** solid-state design offers enhanced control capability and substantial savings in scheduled maintenance as a result of the drastic reduction in moving parts. Due to the integral braking characteristic of the motor, no mechanical brake assembly is required. The motor may be cycled as often as electrically possible, and cannot be damaged as a result of overload stalling. In addition, an efficient belt-and-pulley-based drive assembly eliminates the “slop” associated with mechanical gearhead drives.

In the event of power failure, the unit self-locks by means of an acme nut and screw. An open damper firing switch is provided to permit firing under emergency conditions.

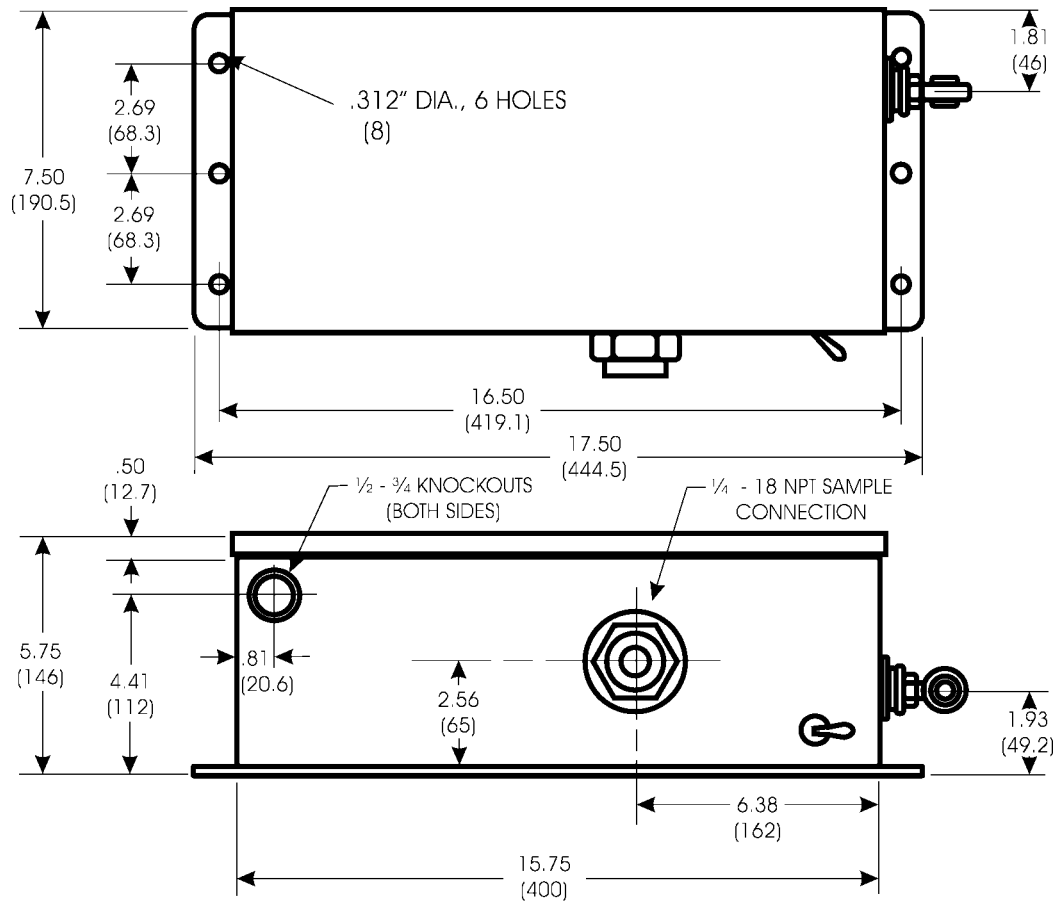

OPERATION

The draft sensing element in all solid-state draft regulators is capable of measuring positive or negative pressure, depending upon how the unit has been set up for the application. The amplifier is temperature compensated, and produces 1-6 VDC output directly proportional to the differential pressure between atmospheric and the process draft or pressure.

Because of the high frequency response of the measuring element, an adjustable electronic damping circuit is incorporated in the controller circuitry to filter out process noise.

The process level signal is compared with the set point by an analog amplifier. The error signal is then processed by hybrid analog/digital circuitry to produce proportional-speed floating control action.

Bi-directional line voltage output for the drive motor is presented through zero-crossover-switching onboard solid-state relays. Drive tube position feedback is not required.

Non-Sequencing Models:

Damper position is modulated in such a way as to maintain the overfire draft at the set point selected for greatest combustion efficiency. A continuous sample of overfire draft is applied to the sensing element, which accordingly actuates the circuitry to advance, stop, or reverse the drive motor. Modulation continues as long as power is applied to the unit.

Sequencing Models:

These units are equipped with the additional circuitry required to permit interlocking with a burner management system. On call for heat from the boiler operating controls, an onboard relay is energized that powers the motor, driving the damper fully open. An auxiliary limit switch then closes, permitting the flame programmer to start its cycle. After the pilot flame has been proven, the main fuel valve begins to open, and simultaneously, another onboard relay is energized that places control on modulation. Modulation continues until the combustion control system shuts off the burner. The damper is then driven to the fully closed position, and remains closed until the next call for heat.

In the event of flame failure (and the boiler limits are not made), the drive arm will retract, moving the damper to the fully closed position.

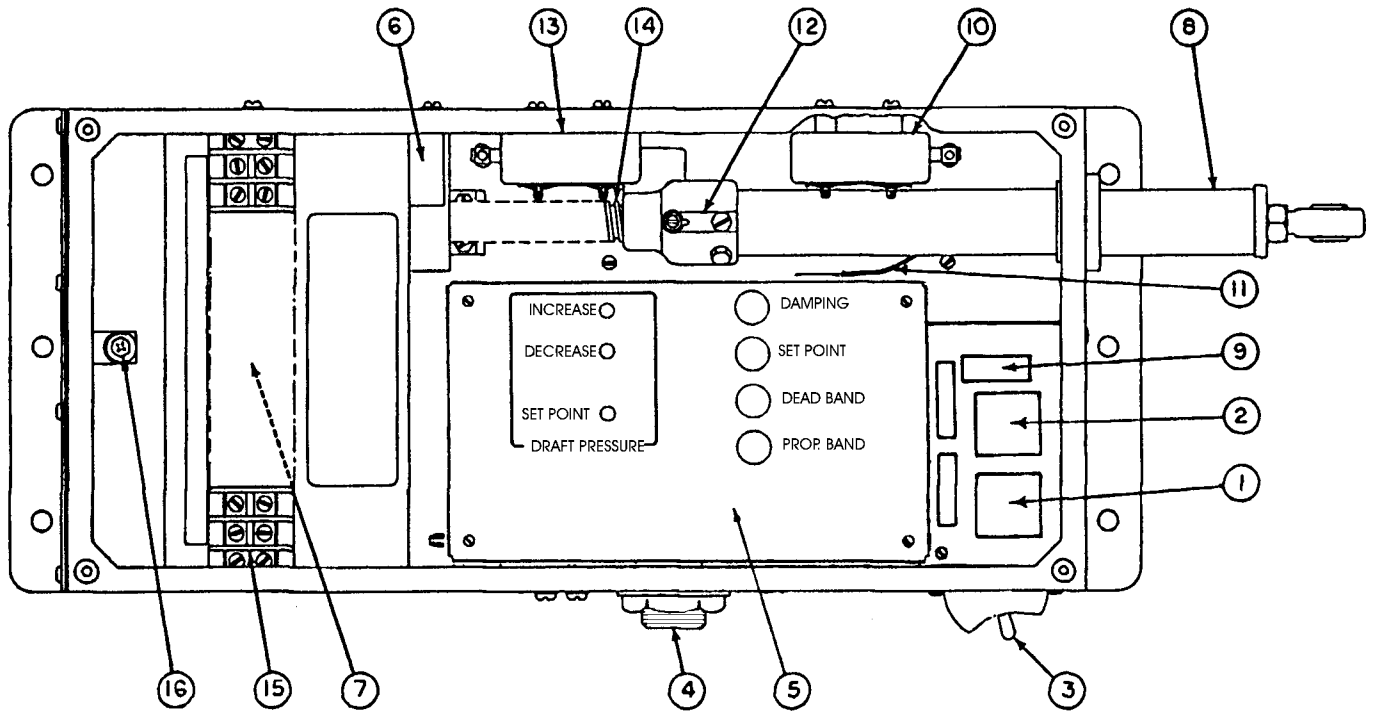

Model R - 09500 - B0 Draft Regulator Interior View

1. Relay 1 (P/N 26624) opens damper.
2. Relay 2 (P/N 26624) places control on modulation.
3. Automatic/Open-damping Firing selector switch.
4. Sample Connection: ¼-inch NPT female fitting.
5. Electronic sensor/controller section.
6. Motor capacitor and resistor assembly.
7. Motor (behind guard).
8. Thrust arm with rod end bearing.
9. 1-ampere rated fuse (P/N 10956).
10. End switch: outward travel limit (P/N 10999).
11. Auxiliary end switch (P/N 10999).
12. Traveling switch trip with lubrication fitting.
13. End switch: inward travel limit P/N 10999).
14. Acme drive screw.
15. Wire-clamp terminals for all external wiring connections.
16. Ground screw connection.



HOW TO ORDER

The basic catalog number for the **Hays Cleveland Model R-09500-B0 Draft Regulator** is shown below. Replace suffixes A through F with the desired selections from the table below.

R-0950A-BCD-E-F

A. Nominal Stroke Time/Thrust Range:

- 30 seconds/75 lbs. at 60 Hz
[Available with solid-state models only; select "2" in section E]
- 60 seconds/150 lbs. at 60 Hz
[Standard]
- Special

B. Operating Mode:

- Sequencing
- Non-Sequencing

C. Manual Operator:

- None
- Handwheel

D. Power Requirement:

- 120 v 50/60 Hz.
- 240 v 50/60 Hz.

E. Solid-State Upper Section:

- Piezo-resistive sensing element and all-electronic integral control function.

F. Current Model Designation: B

PHYSICAL

Power Requirements: 120 v AC 50/60 Hz. or 240 v AC 50/60 Hz. models, standard.

Mounting: Mount on a flat, rigid surface. Locate and position so that thrust arm is fully retracted when damper lever places damper in fully closed position. Select location where radiant or ambient temperature is not excessive. Mount within six feet of floor to facilitate adjusting and maintenance. **DO NOT MOUNT ON BOILER WALL OR BREECHING.**

Motor: 72 RPM stepping motor operated in synchronous mode.

Sample Connection: 1/4" NPT female fitting.

Ambient Temperature Range: 0 to 140F (-19 to 60C).

Finish: Wear-resistant sealed black polyurethane enamel.

Shipping Weight: 30 lbs. Carton dimensions: 6.5" x 9.5" x 20.75".

SPECIFICATIONS

APPLICATION

Travel: Six-inch linear travel.

Stroke Time: Nominal 60-seconds full stroke time at 60 Hz.

Thrust: 150 lbs. (equivalent to 37.5 ft. lbs.*).

End Switches: High and low end limit switches standard. Auxiliary limit switch on sequencing models.

Manual Operator: Continuous rotation-type handwheel optional.

Set Point: Adjustable, 0 to +2.0" w.c., or 0 to -2.0" w.c. (field-selectable ranges).

Damping: Adjustable, 1.5 to 15 seconds for 90% response to a step change.

Proportional Band: Adjustable, 0.03 to 0.2" w.c.

Dead Band: Adjustable, ±0.01 to 0.08" w.c.

*Foot-pound ratings in this bulletin indicate equivalent torque developed by a rotary actuator with a 3" lever traveling through 90 degrees. They are included for reference and comparison purposes only.

Specifications Subject to Change.



Are you reading a FAX or a COPY of this bulletin? DOWNLOAD the full-color PDF version of this and other literature at our website!

Visit us on the World Wide Web at www.hayscleveland.com

Hays Cleveland Div. of UniControl Inc.
1903 South Congress Avenue
Boynton Beach FL 33426
Telephone: 561.734.9400
Fax: 561.734.8060
email: salescombustion@unicontrolinc.com

Hays Cleveland Div. of UniControl Inc.
1111 Brookpark Road
Cleveland OH 44109
Telephone: 216.398.4414
Fax: 216.398.8558
email: salescombustion@unicontrolinc.com